

## Data flow vs. logical dependencies

- ▶ In robotics, we are used to think about **data flow**:

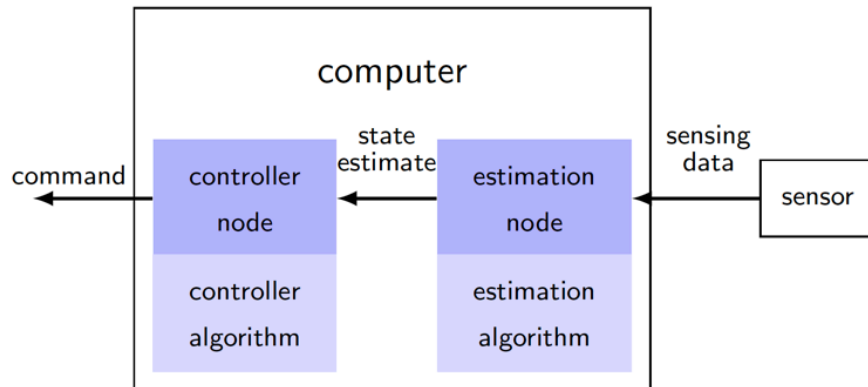

- ▶ To find **components**, it helps to reason about **logical dependencies**:

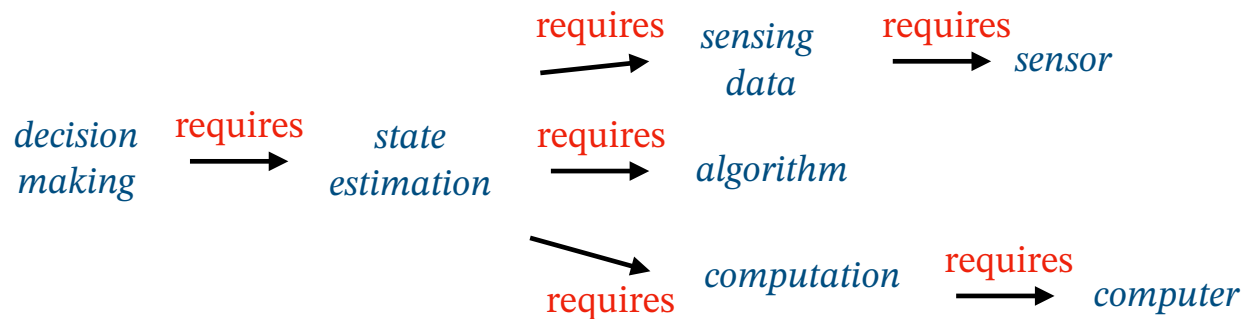

*But **why** do we need a computer?*



# Context informs the level of detail

- ▶ Different scenarios will need different levels of detail.

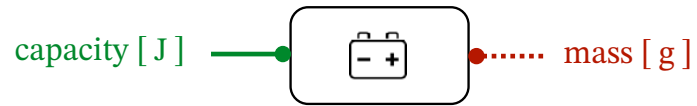

*“back of the envelope calculation”*

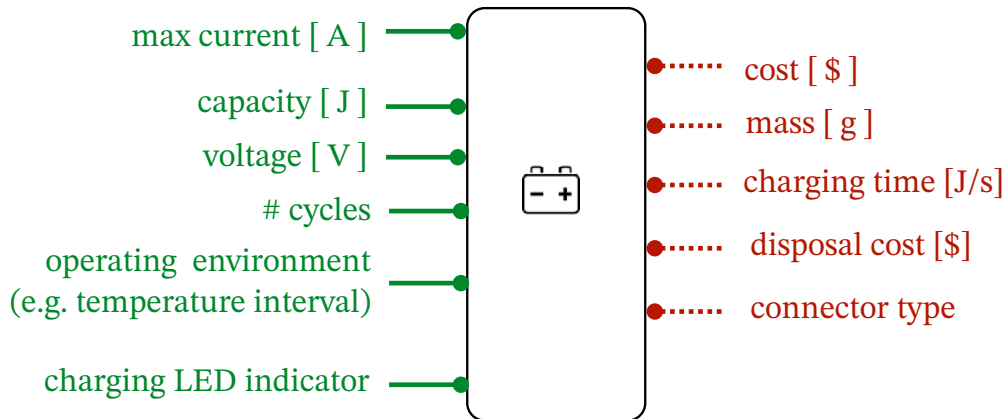

*“vendor selection”*

# Use case: Co-design of an autonomous drone

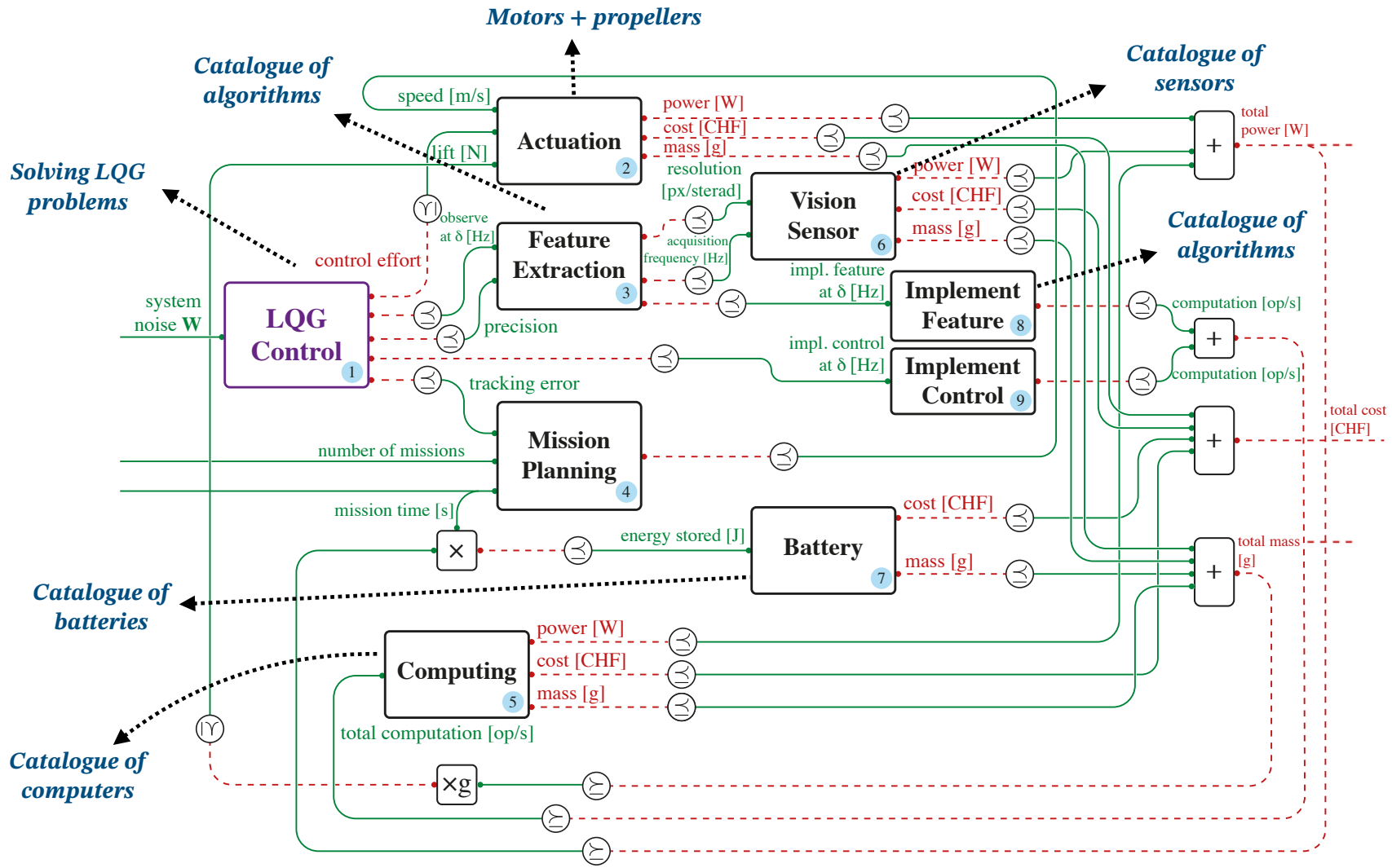

# Co-design of an AV

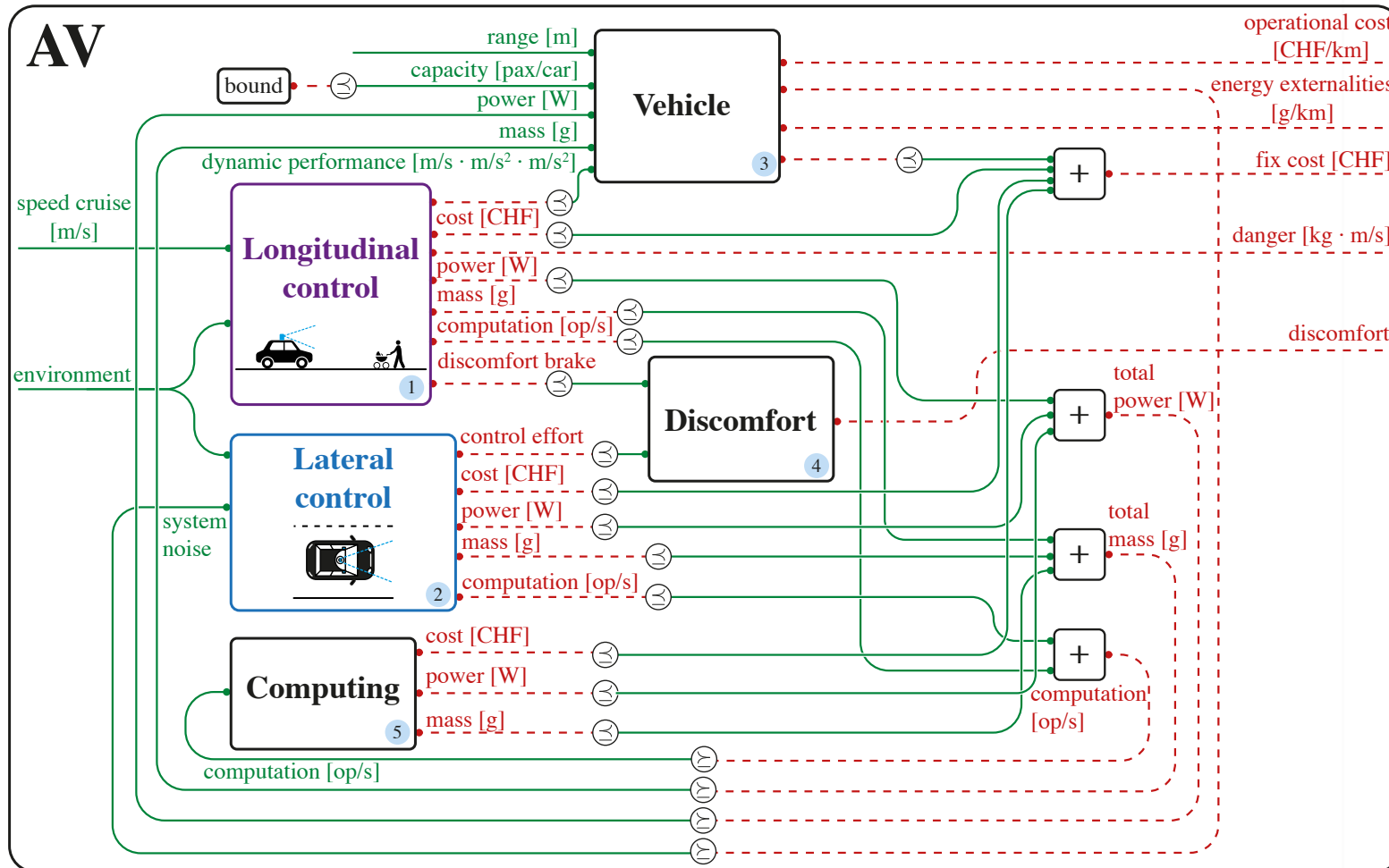

# Functional decomposition

